

TECHNISCHE DATEN • technical data • dati tecnici • caractéristiques techniques

Breite (Einbaumaß Korpus) width (fitting measure body) • larghezza • largeur (dimension du corps de l'appareil)	550 mm
Türrahmenhöhe height doorframe • altezza antina • hauteur du cadre de porte	510 / 570 mm
Türformen door • versione antina • forme de la porte	Ecke 90° • corner 90° • angolo 90° • angle 90°
Breite width • larghezza • largeur	613 mm
Tiefe depth • profondità • profondeur	614 mm
Höhe height • altezza • hauteur	1230-1430 / 1290-1490 mm
Gewicht weight • peso • poids	150 / 157 kg
Nennwärmeleistung lt. EN 13229 nominal heat output according to EN • resa nominale secondo norme EN • puissance de chauffage selon EN	7 kW
min. / max. Heizleistung min. / max. heat output • potenzialità termica effettiva • puissance de chauffage	3,5-9 kW
Rauchrohrabgang flue pipe outlet • diametro uscita fumi • sortie de tuyau de fumées	Ø 180 mm
Abgasmassenstrom flue gas mass flow • flusso fumi • flux massique de gaz d'échappement	7,5 g/s
Abgastemperatur flue gas temperature • temperatura fumi • température de gaz d'échappement	330 °C
Mindestförderdruck minimum feed pressure • depressione min. necessaria • pression de transport minimum	14 Pa
Umluftquerschnitt ohne / mit metallischer Nachheizfläche convection air cross section without/with metallic heat exchanger • sezione trasversale aria convettiva senza/con scambiatore di calore metallico • section arrivée d'air sans / avec surface de chauffe métallique	700 / 1100 cm²
Dämmschichtdicken Promasil 950 KS (Boden / Seite / hinten / Decke*) insulation thickness Promasil 950 KS (floor / sides / rear / ceiling*) • spessore isolante Promasil 950 KS - silicato di calcio (inferiore / laterale / posteriore / superiore*) • épaisseurs d'isolant Promasil 950 KS (sol / côté / arrière / en haut*)	0 / 60 / 60 mm
Geschlossene Anlage möglich closed construction possible • installazione ermetica possibile • installation hermétique possible	ja • yes • si • oui
Keramische Züge: Länge maximal connection to ceramic flue heat exchangers: length max. • convogliamento in scambiatore ceramico: lungo massimo / refrattario • circulation d'air chaud dans canalisation céramique: longueur max.	4 m
Schiebetür sliding door • apertura a scomparsa • porte coulissante	✓
Doppelscheibe double glass • doppio vetro • double vitrage	✗

55x55x51S - Art. no. 3600022



55x55x57S - Art. no. 3600023

Maßstab 1:20

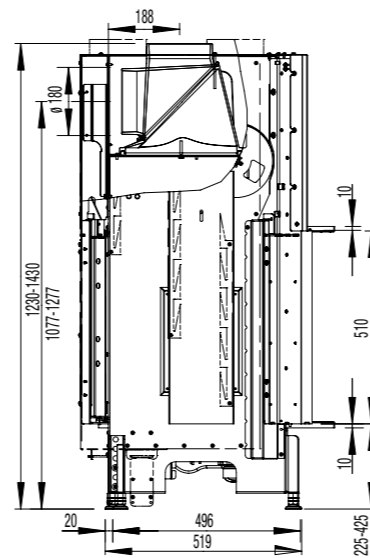
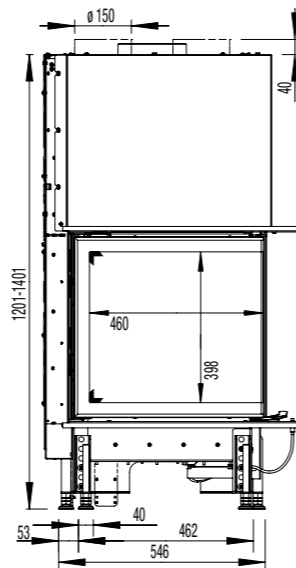

Maßstab 1:10

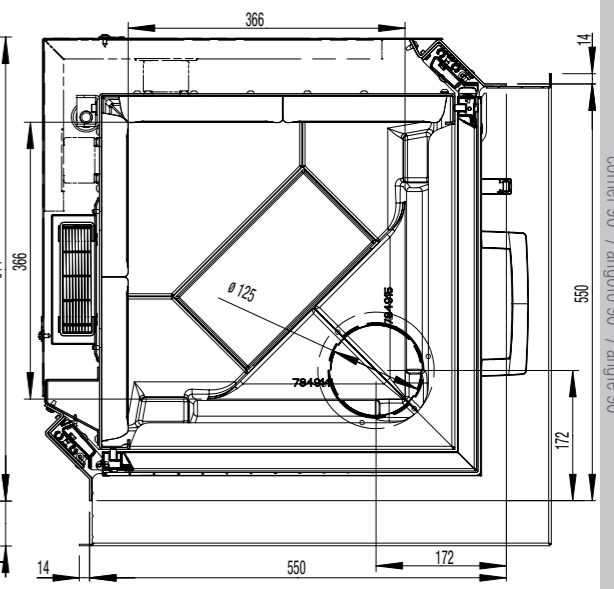
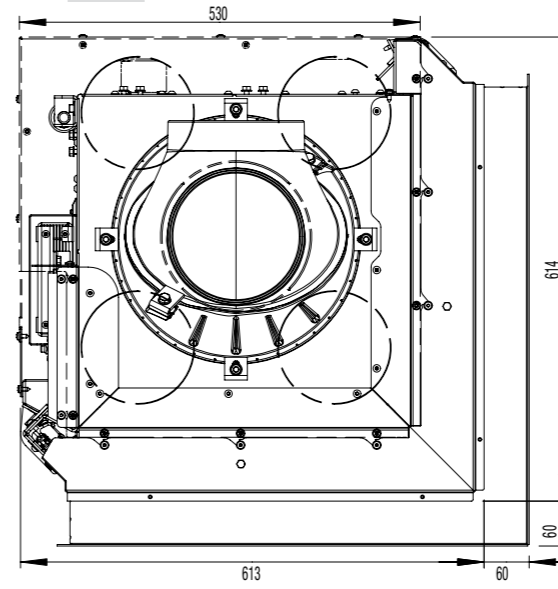

Maßstab 1:20

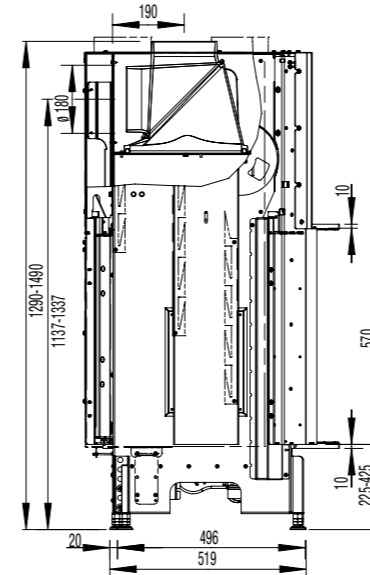
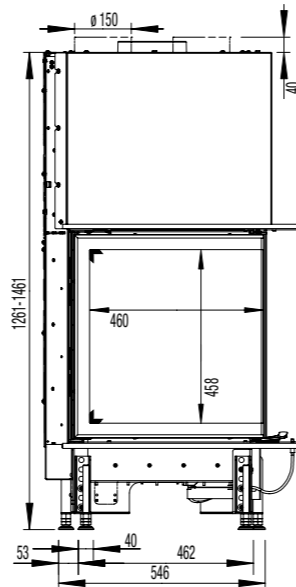

Maßstab 1:10

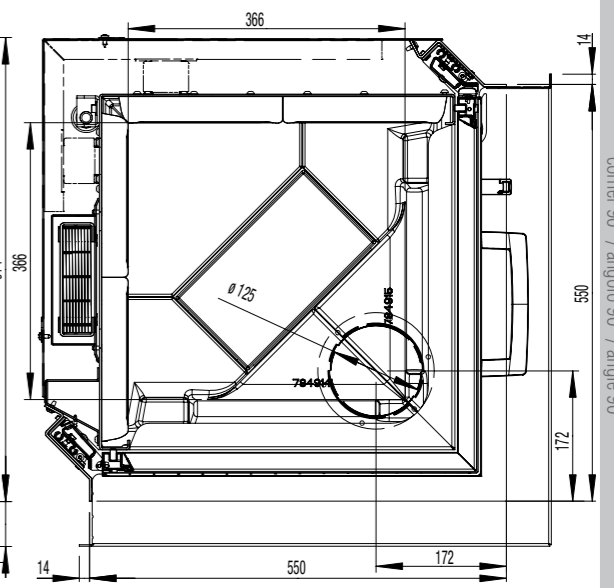
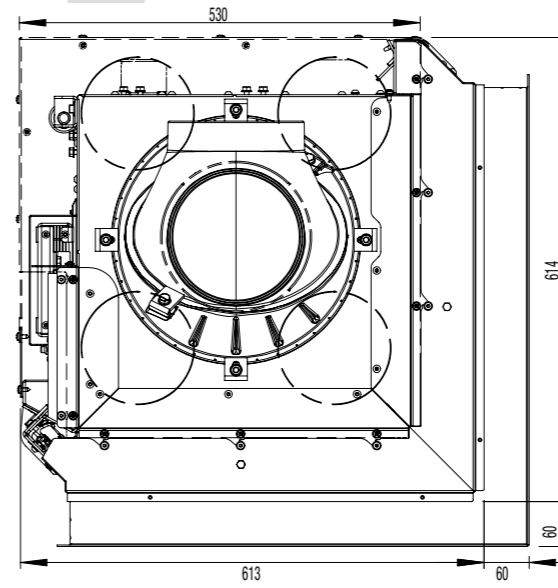

510 Ecke 90°
corner 90° / angolo 90° / angle 90°

570 Ecke 90°
corner 90° / angolo 90° / angle 90°

Stand: 07/2015